

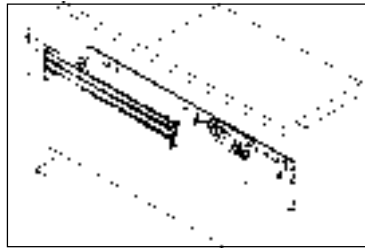

APPLICATIONS: Box and file drawers, 24" wide or less. Use in shallow as well as deep drawers in desks and other medium duty storage applications. Vertical drawer adjustment with rail cam. **This product is covered by U.S. and various foreign patents issued and/or pending.**

Progressive Movement
Vertical Cam Adjustment
Low Profile, Rail Disconnect
100 lb. [45.5 kg.] Capacity**



Handed Rail
Left Hand Shown.
Right Hand Opposite.

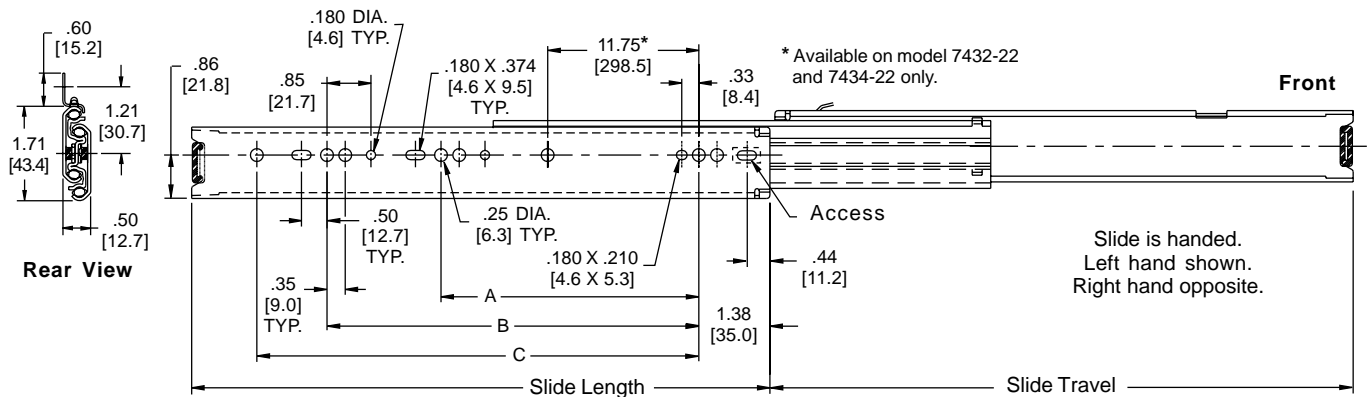
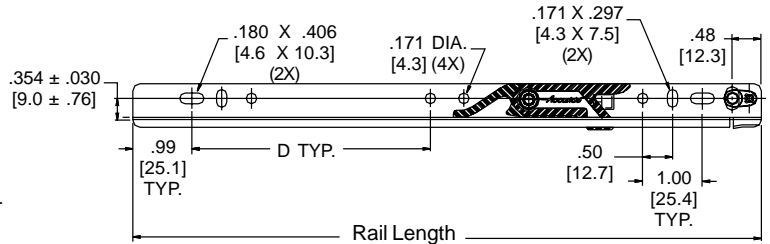

INCHES
[mm]

- Finish** Bright electro-zinc (C) or black zinc \square (CB)
- Length** 12" to 28" [300mm to 700mm]
- Height** 1.71" (2.31" including rail)
[43.4mm] ([58.7mm including rail])
- Travel** See chart
- Load** 100 lbs. [45.5 kg.] per pair**
- Side Space** .50" + .030 / - .000
[12.7mm + 0.76 / -0.00]
- Mounting** Side, handed rail with cam adjustment
- Disconnect** Rail
- Movement** Progressive action, steel ball bearings
- Hardware** #8 pan head or binding head screw, or M-6 Euro screw, or Accuride screw provided in D-Pack
- Features** 32mm and traditional hole pattern, positive stop, detent closed, handed, silenced open and closed

Slide Part Number	Actual Slide Length	Slide Travel 7432	Slide Travel 7434	A	B	C	D
7432-12	11.81 [300]	12.00 [305]	12.97 [329]	8.82 [224]			4.00 [102]
7434-12							
7432-14	13.78 [350]	13.97 [355]	14.94 [379]	8.82 [224]			4.00 [102]
7434-14							
7432-16	15.75 [400]	15.93 [405]	16.92 [430]	12.60 [320]			4.00 [102]
7434-16							
7432-18	17.72 [450]	17.90 [455]	18.89 [480]	13.86 [352]			4.00 [102]
7434-18							
7432-20	19.69 [500]	19.87 [505]	20.86 [530]	12.60 [320]	16.38 [416]		4.00 [102]
7434-20							
7432-22	21.65 [550]	21.84 [555]	22.81 [579]	13.86 [352]	17.64 [448]	18.90 [480]	7.00 [178]
7434-22							
7432-24	23.62 [600]	23.81 [605]	24.78 [629]	15.12 [384]	18.90 [480]		7.00 [178]
7434-24							
7432-26	25.59 [650]	25.78 [655]	26.76 [680]	15.12 [384]	21.42 [544]		7.00 [178]
7434-26							
7432-28	27.56 [700]	27.75 [705]	28.73 [730]	16.38 [416]	21.42 [544]	23.94 [608]	7.00 [178]
7434-28							

Rail Part Number	Rail Length	Fits Slide Length
7156-1214-CL & 7156-1214-CR	10.54 [268]	12" & 14"
7156-1518-CL & 7156-1518-CR	13.06 [332]	16" & 18"
7156-1921-CL & 7156-1921-CR	16.84 [428]	20"
7156-2225-CL & 7156-2225-CR	20.62 [524]	22" & 24"
7156-2628-CL & 7156-2628-CR	24.40 [620]	26" & 28"

\square Minimum order quantities may apply.
** Load rating based on an 18" slide on a 24" wide drawer cycled 75,000 times.

C (clear zinc) or B (black zinc) L (left hand) or R (right hand)

Installation Instructions

Conventional Mounting - Cabinet Member Installation

1. Mark horizontal line in cabinet sidewall at least 7/8" up from cabinet floor. (Slide may be gauged on cabinet floor.) Mark point on line 7/16" in from cabinet front. This will position slide flush with the cabinet opening. For inset drawers, add drawer front thickness to 7/16" dimension. See Figure 1.
2. Measure distance between front and rear horizontal slots on slide. Mark this measurement on horizontal line beginning at the first mark.
3. Make pilot hole on each mark with an awl or 3/32" drill.
4. Install #8 pan, binding head, or special screw (provided in D-Pack) through front and rear horizontal slots.

32mm System - Cabinet Member Installation

1. Install M-6 Euro screw through second 6mm diameter hole from front of slide and into the 5mm hole in cabinet located 37mm from front face of cabinet. Select rear mounting hole on one of the 32mm multiple provided. Install screws. See Figure 2.

Conventional and 32mm System - Rail Installation

1. Mark horizontal line on drawer side 1-7/32" [30.7] above cabinet member holes center line.
2. Mark point on this line 5/8" [15.9] back from drawer front. Install a #8 screw through the cam adjuster and through a slot at the rear. See Figure 3.

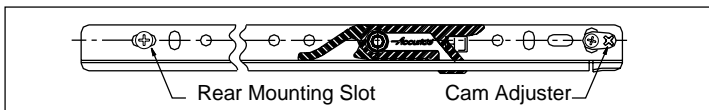

NOTE: The cam screw must install on the same center line as the remaining rail mounting screws. This eliminates additional measuring and marking and maximizes adjustment range.

3. Connect the drawer to the extended slide members by lowering the drawer onto the slides so the rail lock arm rests on top of slide members approximately 1.00" [25.4] from the front. Pull both slides forward until rail latch locks securely into each slide.

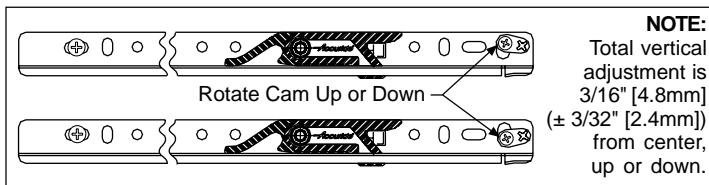

4. Rotate the cam with a Phillips or Pozi screwdriver to vertically position the drawer in relation to the cabinet.

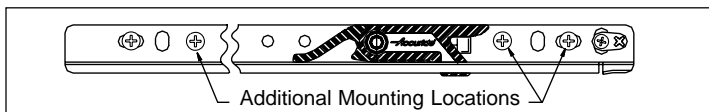

5. **IMPORTANT:** After all adjustments are made, secure rail with additional mounting screws.

Packaging

Distributor (D) Pack: All lengths are packaged 5 pair per box. Polybag includes 1 pair of slides, handed rails, and screws.

X-Press (X) Pack: All lengths are packaged 5 pair per box. Slides, mounting rails, and screw packaged in one box.

Bulk Pack: All lengths are packaged 10 each per box. Slides and rails are packaged lefts in one box and rights in one box.

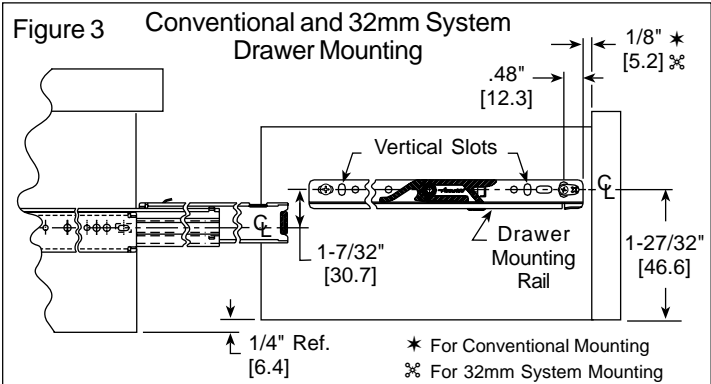
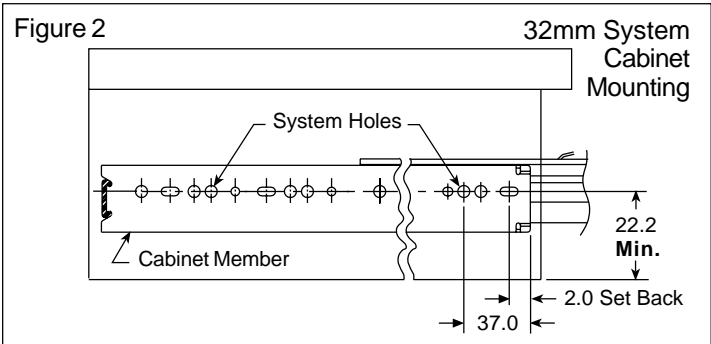
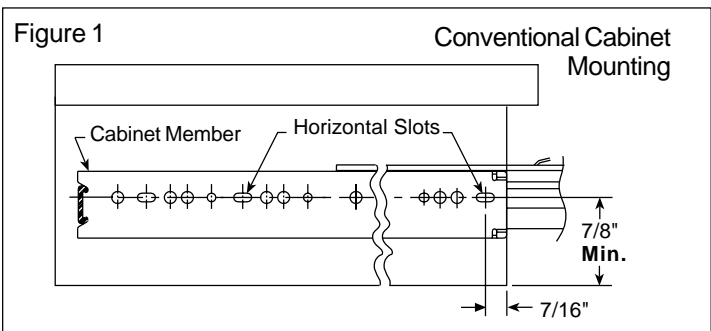

Slide and Rail Ordering Instructions

Complete your slide order for Accuride Model 7432 or 7434 by specifying the total slides required, slide finish, slide model, slide length, and optional polybag packaging.

Example: 50 Pair C 7432 -18 D

Complete your bulk rail order by specifying the quantity, rail part number rail finish: "C" for zinc; "B" for black, and hand: "L" for left hand; "R" for right hand.

Example: 50 Each 7156-1518 -CL and -CR

Specifications

Slide members and ball retainers: Cold rolled steel
Ball bearings: Carburized steel

NOTE: Specifications, materials, prices, terms, and delivery are subject to change without notice.

Accuride

ACCURIDE INTERNATIONAL INC.

12311 Shoemaker Avenue
Santa Fe Springs, CA 90670

TEL (562) 903-0200
FAX (562) 903-0208
www accuride.com

Manufacturing, Engineering, and Sales
United States • Germany • Japan • Mexico • United Kingdom