

TANDEM plus 568F / 568A heavy duty drawer runners

Overlay application

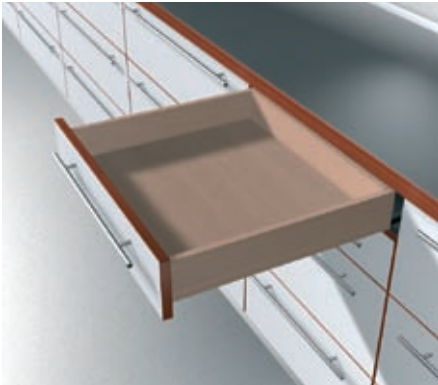

Description

- Full extension concealed drawer runners
- With integrated BLUMOTION
- For 19 (3/4") max. drawer side thickness
- Frame applications must be blocked out
- Rear tilt adjustment
- Concealed roller carriages with permanently lubricated synthetic rollers create a smooth running action
- Locking devices enable easy drawer insertion and removal
- Force guided right side and ± 1.5 (1/16") tolerance compensating left side
- Dynamic weight capacity of 110 lb
- Static weight capacity of 125 lb

Basic components

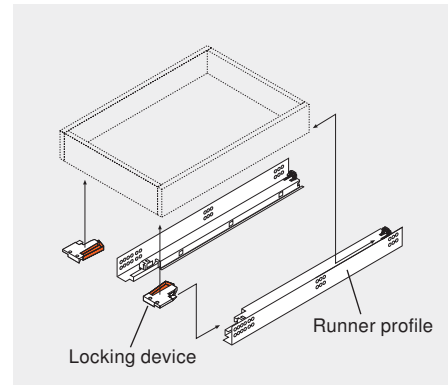

Other applications

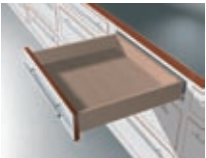

Inset drawer **pg. 27**

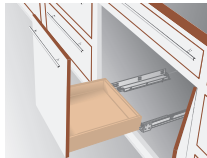

Bottom mount **pg. 32**



SPACE CORNER **pg. 33**



ORGA-LINE **pg. 35**



Deep drawer **pg. 39**

Components

Profile set

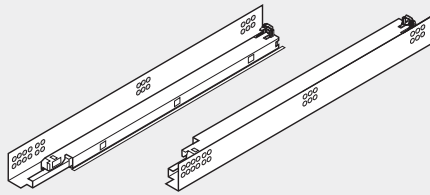

One set required per drawer

For overall cabinet depth	Drawer length	Over extension	TANDEM plus BLUMOTION
533 (21")	457 (18")	0	568F4570B
610 (24")	533 (21")	0	568F5330B
686 (27")	610 (24")	19 (3/4")	568A6100B
762 (30")	686 (27")	20 (13/16")	568A6860B
838 (33")	762 (30")	28 (1-1/8")	568A7620B

Note: These runners are for 19 (3/4") max. drawer side thickness

Standard locking device

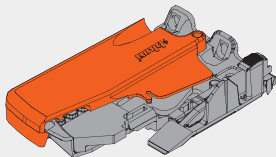

- One right and one left required per drawer
- Minimum interior drawer width 121 (4-3/4")
- Height adjustable +3 (1/8")

Installation
page 14

Right	T51.1700.04 R
Left	T51.1700.04 L
Installation screws	612TH

Using TANDEM

page 13

Drawer preparation

page 14

Accessories

page 41

Assembly aids

page 43

Extension	Full
Max. drawer material	19 (3/4")
Dynamic capacity	110 lb.
Static capacity	125 lb.

Drawer and cabinet specifications

Front view

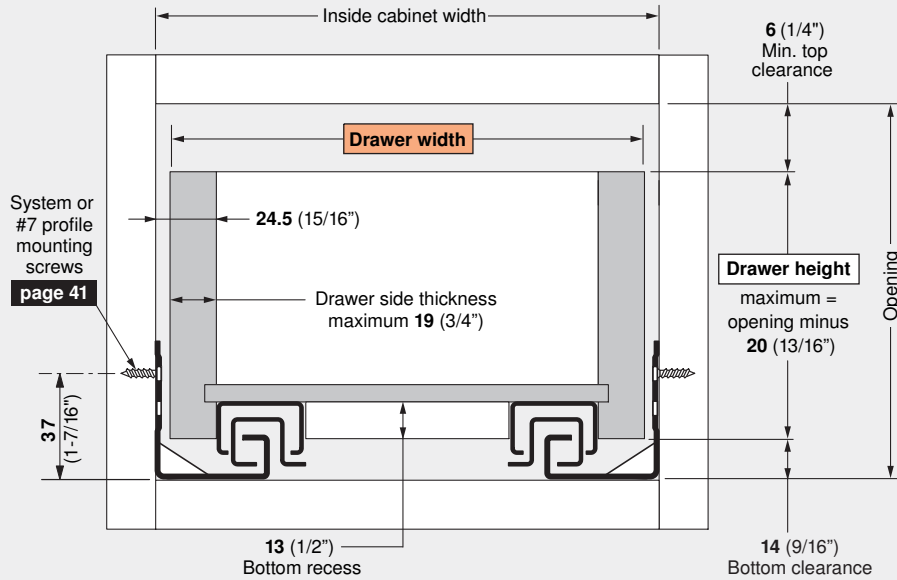

Drawer back preparation

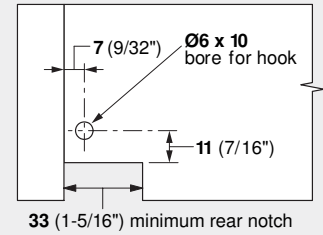

Note: Frame applications must be blocked out

Formula for calculating outside drawer width

For drawer side thickness	19 (3/4")	18 (23/32")	17 (21/32")
Deduct from inside cabinet width	11 (7/16")	13 (1/2")	14 (9/16")

Example: For 21" inside cabinet width and a 3/4" thick drawer, 21" minus 7/16" = 20-9/16" drawer width

Profile mounting specifications

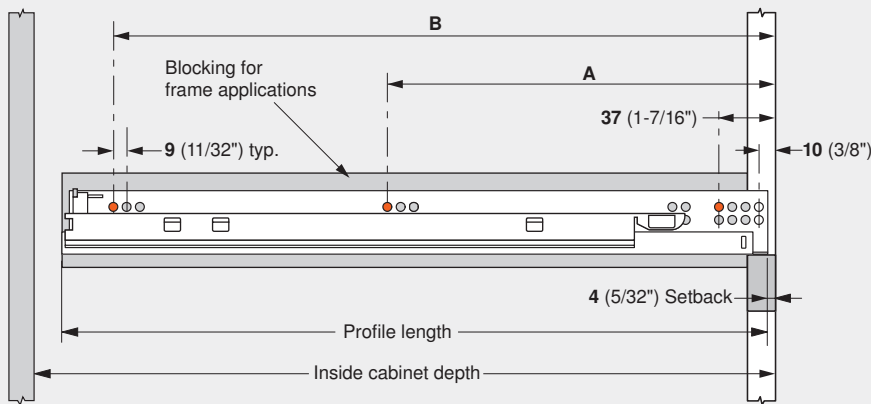

Profile close-up

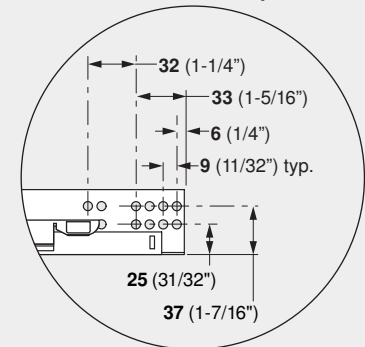

TANDEM plus BLUMOTION	Drawer length	Minimum inside cabinet depth	Profile length	System screw locations	
				A	B
568F4570B	457 (18")	477 (18-3/4")	470 (18-1/2")	261 (10-1/4")	453 (17-13/16")
568F5330B	533 (21")	553 (21-3/4")	546 (21-1/2")	261 (10-1/4")	517 (20-3/8")
568A6100B	610 (24")	633 (24-15/16")	626 (24-11/16")	261 (10-1/4")	389 (15-5/16")
568A6860B	686 (27")	703 (27-11/16")	696 (27-7/16")	261 (10-1/4")	389 (15-5/16")
568A7620B	762 (30")	778 (30-5/8")	771 (30-3/8")	261 (10-1/4")	389 (15-5/16")