

44 STANDARDS & 485 BRACKETS SPECIFICATION INFORMATION

This sheet conforms to editorial style prescribed by
The Construction Specifications Institute.

1. PRODUCT NAME

44 Wall Standard.
485 Shelf Bracket.

For shelving applications for industrial, commercial, retail, and residential use.

2. MANUFACTURER

Reeve Store Equipment Co.
9131 Bermudez St
Pico Rivera, CA 90660
(562) 949-2535
www.reeveco.com

3. PRODUCT DESCRIPTION

Basic Use: 44 Wall Standards and 485 Shelf Brackets are manufactured for storage and display applications in retail stores, grocery stores, warehouses, industrial, repair garages, maintenance storage, business office storage, residential storage, and other heavy-load situations. Load rated at 145-385 pounds.

Recommended screws are #10 x 3" flat head screw.

Composition and Materials:

44 standard = 14-gauge cold rolled steel.

485 bracket = 13-14-gauge cold rolled steel.

Sizes: 44 Standards:

1 1/4" wide x 1/2" high with 1" slot adjustment.

Stock lengths: 2', 2.5', 3', 4', 5', 6', 7', 8', and 10'.

485 Brackets: 485 Brackets are used for shelf depths of 8", 10", 12", 14", 16", 18", 20", 22", and 24".

Finishes: Brillatone (Satin Zinc).

Available in other plated and/or powder coated finishes upon request.

4. TECHNICAL DATA

Applicable Standards:

Standards and brackets are tested to meet or exceed ANSI performance

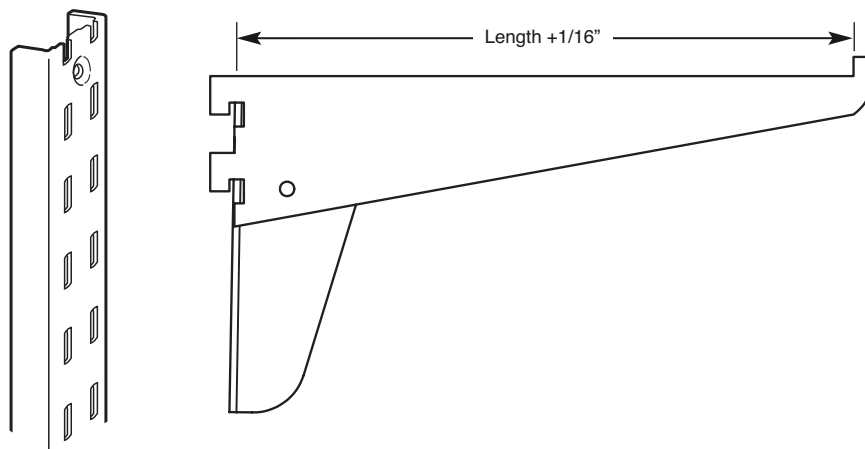

44 Standards:

Product Number	Product Finish	Available in the following lengths (feet):								
		2	2 1/2	3	4	5	6	7	8	10
44	Brillatone (Satin Zinc)	●	●	●	●	●	●	●	●	●
44	Brass	●	●	●	●	●	●	●	●	●

485 Brackets:

Product Number	Product Finish	Available in the following lengths (inches):								
		8	10	12	14	16	18	20	22	24
485	Brillatone (Satin Zinc)	●	●	●	●	●	●	●	●	●

Key: ● = Available

standards as established by BHMA in the Reeve recommended application.

These load limits are intended to be used as general guidelines only, and no warranty (expressed or implied) is made by Reeve, as to the actual results that will be obtained in your specific application.

Results were obtained by laboratory testing in accordance with ANSI/BHMA A156.16 performance standard. In addition, Reeve's standards and brackets have been approved by the **Woodwork Institute (WI)** as meeting or exceeding their performance standards. Testing performed by **Underwriters Laboratories (UL)**. (Load ratings based

on standards being mounted to wood wall studs on 16" centers. Wider spacing will result in reduced load capacity.) Actual results may vary. Actual use conditions will typically result in lower load capacity than laboratory conditions.

Representative testing in a fully configured application is the only way to assure proper performance, durability, and safety. Contact Reeve for verification testing service of your specific application.

Environmental Considerations:

Environment: Excessive humidity, salts, or other chemical agents can corrode the finish and attack metal.

REEVE
 STORE EQUIPMENT CO.
 (800) 927-3383

REEVE
 STORE EQUIPMENT CO.
 (800) 927-3383

Fastening: Inadequate or incorrect fasteners can result in the standard pulling loose and causing damage.

Alignment: Improper standard/bracket alignment can result in a shelving system that is ineffective and unsafe.

5. INSTALLATION

For maximum loading capacity, standards should be mounted directly to wall studs, which are generally found at 16" intervals. (If standards will not be mounted to studs, use appropriate wall anchors.)

Use the recommended fasteners (#10 x 3" flat head screws) in all holes to properly secure the standard. Use other proper fasteners if installing to substrate other than wood stud. Prior to drilling all holes, check to be sure that the standard is vertically level.

Place the bracket into the standard slots. Using a rubber mallet, tap lightly near the bracket's base. The bracket will snap into place.

6. AVAILABILITY AND COST

Availability: Reeve products are available from stocking distributors and through Reeve Representatives worldwide.

Cost: Current pricing is available from area Reeve Representatives. Please call for the nearest representative: (800) 927-3383.

7. WARRANTY

Limited Lifetime Warranty:

Reeve warrants that goods manufactured and sold by it are free from defects in material or workmanship at the time sold by Reeve. Complete warranty details are available upon request. Reeve's liability shall be limited to repair or replacement upon written notice to the company within 30 days of the discovery of defective condition. Reeve expressly disclaims all other

warranties, including any warranty of merchantability or fitness for a particular purpose. Reeve will not be liable for incidental or consequential loss or damage due to improper application or installation.

8. MAINTENANCE

44 Wall Standards and 485 Shelf Brackets require no maintenance. Inspect for proper fit periodically, and adjust when necessary. Replace as required or recommended by application.

9. TECHNICAL SERVICES

Reeve and area representatives can assist with any application. For further information, or for the name of the representative nearest you, please call Reeve Customer Service: (800) 927-3383. Or visit our website at: www.reeveco.com.

10. FILING SYSTEMS

Additional product information, data sheets, application sheets, and a full catalog are available for all installations upon request from Reeve.